

1. Exhibitor Eligibility / Booth Details

1-1. Exhibitor eligibility

Companies/organizations involved with products or related businesses included in the following list are eligible to participate in CEATEC (hereinafter may be referred to as the Exhibition):

- | | | |
|---|---|---|
| 1. IT & electronics equipment related | 11. Machinery manufacturing related | 21. Educational and research institutions and organizations |
| 2. Electronic parts, devices, materials, raw-materials, and apparatus related | 12. Housing Construction, real estate related, developer business | 22. Government organization, administrative corporations, public interest corporations, nonprofit public and industry organizations, public service-related companies |
| 3. Broadcasting and information/communications related | 13. Trading company and wholesalers handling the businesses listed from 1. to 12. | 23. Members of the three sponsors (JEITA, CIAJ, and CSAJ) are also eligible to participate. |
| 4. Software and content related | 14. Logistics and transportation related | 24. Other companies approved by the Organizing Committee (Refer to section 8-3. Organizing Committee) |
| 5. Automotive, mobility related | 15. Distribution and retailing related | |
| 6. Public infrastructure related | 16. Apparel related | |
| 7. Healthcare related | 17. Sporting related | |
| 8. Energy related | 18. Tourism related | |
| 9. Financial related | 19. Service related | |
| 10. Agricultural and forestry related | 20. Media including newspaper, magazines, etc. | |

- (1) Advertising companies and other related agencies are not allowed to represent any company that exhibits products even if said products are included in the aforementioned list of eligible businesses or products.
- (2) The CEATEC Organizing Committee (Refer to section 8-3. Organizing Committee) reserves the right to refuse applications from companies that have violated regulations at a previous show or whose activities may be considered detrimental to visitors and/or other exhibitors regardless of in prior to or after holding an exhibitor contract. In such case, paid booth fees will be refunded. (Refer to section 5-3. Exhibit application and contract agreement.)

1-2. Exhibit Areas

- (1) CEATEC will be divided into the following exhibit areas.
- | | |
|---------------------------------|--------------------|
| ■ Company/Organization Exhibits | ■ Planned Exhibits |
| ● Total Solutions | ● Society 5.0 TOWN |
| ● Smart X | ● Co-Creation PARK |
| ● Devices & Technologies | |

Note: Application guidelines are different for each planning in the Planned Exhibits (Society 5.0 TOWN, and Co-Creation PARK) (Refer to page 12 to 15.)

- (2) An exhibitor can request a single zone or, if more than one booth is planned, multiple zones. If choosing multiple zones, please submit a copy of the Exhibition Application/Contract Form for each zone.
- (3) Area composition will be decided based on the exhibition zones listed in the Exhibition Guidelines and Exhibitor Application/Contract Form. The composition and names of each area will be announced at a later date following the decision of the Organizing Committee.

*Please note that a area for which there is an insufficient number of exhibitors may be merged with another area.

2. Exhibit application and contract agreement

To apply for exhibition space, fill in the information required on the Exhibition Application Form, and submit the form to Japan Electronics Show Association, which is the CEATEC Management Office (hereinafter may be referred to as the Association). The Association will confirm its receipt of the application by e-mail. The receipt date stated in this confirmation e-mail is regarded as a contract date, and exhibitors are liable for the participation fee.

- (1) Send applications to

CEATEC Management Office (Japan Electronics Show Association [JESA])

5F Ote Center Bldg., 1-1-3 Otemachi, Chiyoda-ku, Tokyo 100-0004 TEL: +81-3-6212-5233 FAX: +81-3-6212-5226

- (2) Start of acceptance of applications

Tuesday, February 19, 2019 10:00a.m. (JST)

Note: Application will not be accepted before the stated date/time.

- (3) Application deadline

Friday, April 26, 2019

Notes: Exhibition applications will be accepted, even after deadline, as long as there are booth spaces remaining.

Please understand that the deadline may be earlier than above dates if the number of applications reaches its maximum.

- (4) Submitting a company profile

First-time exhibitors to the show are required to provide a company profile and catalog(s) of product(s) planned to be exhibited upon submission of the exhibit application/contract. And, if there are major changes made to the company profile or catalog(s) of product(s) planned to be exhibited after the exhibitor has submitted these documents, regardless of whether the exhibitor is first-time or returning, an updated profile and/or catalog(s) must again be submitted. Applications without these documents will be put on hold until the Association confirms the receipt of these items.

- (5) Joint exhibitors with two or more

Joint exhibitors should elect one "representative exhibitor" to handle payment of the booth spaces for all participating exhibitors. The Association will send a joint exhibit registration form to the representative exhibitor in July, who should fill it in and submit it to the Association.

- (6) Refusal of application

Applications from any persons involved in bankruptcy, composition, receivership, civil rehabilitation, or corporate reorganization proceedings, or persons who are suspended from current account transactions from financial institutions will not be accepted. Similarly, applications from any persons deemed by the Association to be involved in similar circumstances will not be accepted. If an exhibitor company is found to fall into one of the categories described above after the contract has been concluded, the contract will be voided and that company will not be permitted to exhibit. In such a case, participation fees paid by exhibitors will be refunded. If deemed necessary by the Association, an investigation or inquiry into the surrounding circumstances will be conducted.

3. Booth Fees, Standards, Specifications, and Description

3-1. Standard Booth [Company/Organization Exhibits]

(1) Booth Fee The fees per Standard Booth space are as follow:

General corporate exhibitors (standard rate)	396,000JPY (including consumption tax*)
JEITA, CIAJ, and CSAJ members (member rate)	363,000JPY (including consumption tax*)

*Consumption tax rate effective at the time of the exhibition, October 2019, will be applied.

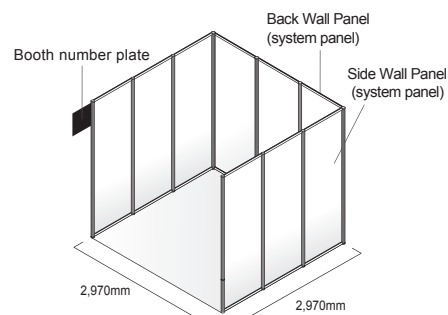

(2) Specifications for 1 to 18 booth spaces (1- to 4-row booths) with Standard Booth

- Dimensions: 2,970 mm (W) x 2,970 mm (D)
- Specifications: For row booth exhibitors, system panels will be installed as back panels on the sides neighboring booths of other exhibitors. However, aisle-side system panels for corner booths and system panels for independent booths will not be installed.

(3) 20 or more booth spaces (Block booths)

The standard for block booths is: 1 booth space = 9m². The floor will be marked in an area equal to (W:D) 2:1 or 1:1 based on the total floor space reserved (9m² x no. of booth spaces). The actual dimensions will be provided to exhibitors at booth allocation lot drawing. Please be sure to take into account when constructing the booth space to make it clear to visitors where the aisles and boundaries are, by installing carpets and the like. Group pavilions composed of 20 or more booths in 1-row or 2-row will apply booth specifications for 3-row/4-row booths.

(4) Booth height limitations

Standard booth height is 2.7m; however, there are height limitations to booth walls as depicted below.

1. 1-row booths (booths 1, 2, 3, 4, 5, 6)

The allowable height of booth walls set back 1.0 m from the aisles and/or foundation panels will be 3.6 m.

2. 2-row booths (booths 4, 6, 8, 10, 12)

The allowable height of booth walls set back 1.0 m from the aisles and/or foundation panels will be 3.6 m.

3. 3-row/4-row booths (booths 9, 12, 15, 16, 18)

In the case of booths with 3 rows or 4 rows, the allowable height of booth walls set back 1.0 m from the aisles and/or foundation panels will be 6.0 m.

Note: Group pavilions composed of 20 or more booth spaces in 1-row or 2-row will apply booth height requirements that are the same as those for 3-row or 4-row booths.

4. 20 or more booth spaces

The height limit is 6 m. Suspended structures less than 6.0 m high is permitted for block booths. The Building frame of the venue must be checked for the installation points for suspended structures.

Note: When posting the company name for row booths exceeding 2.7 m wide, it is prohibited to post the company name on the neighboring booths side to avoid misunderstanding by visitors.

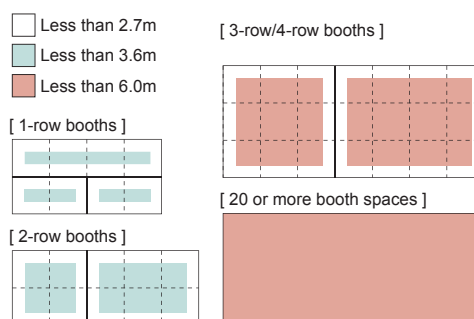

(5) If the height of exhibit product exceeds the height limit

The height limit of exactly and decorations shall be as stated above. However, if the height exceeds the limit due to the nature of the exhibit, please submit the Application for Over-height Exhibits form and booth plan (floor plan & elevation view) to CEATEC Management Office, and obtain permission from the Organizing Committee. In such cases, exhibits are to be displayed within the bounds of your company's booth (setback 1 m from passageways and base paneling), and must not protrude into the space above passageways etc. Permission to exhibit will be granted for exhibits that exceed height limits depending on the materials used etc. Such decorations as company nameplate or product nameplate etc. are forbidden.

3-2. Small Package Booth [Company/Organization Exhibits]

(1) Booth Fee* Small package booth exhibitors may apply for up to two booths.

One booth	187,000JPY (including consumption tax**)
Two booths	374,000JPY (including consumption tax**)

*Includes a package of facilities.

**Consumption tax rate effective at the time of the exhibition, October 2019, will be applied.

(2) Specifications for Small Package Booth

1. Dimensions: 1,980 mm (W) x 990 mm (D) x 2,700 mm (H)

2. Supplied facilities

- Foundation panel
- Display counter (975mm high with storage space)
- Parapet for posting company name (300mm width)
- Cutting sheet lettering for company name display
- Fluorescent light
- Electricity socket (single-phase 100V, up to 1kW output capacity)
- Electric consumption fee (Exhibitor can use up to 1kW of power at free of charge)

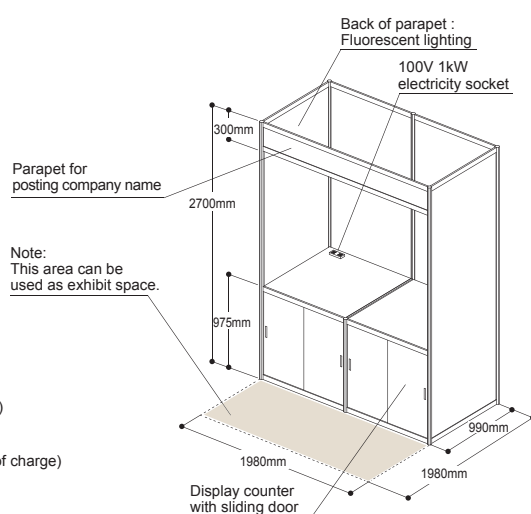

















3-3. Planned Exhibits (Society 5.0 TOWN, Co-Creation PARK)

There is a different application procedure for each area. (Refer to page 12 to 15.)

3-4. Booth Types

At CEATEC there are the following booth types: Standard, Small Package, and Planned Exhibits. Note that the billing statement will list "Exhibit Booth Fee" regardless of the booth type.

3-5. Number of Booth and Booth Type

Booth category	Booth type	Number of booths applied
Standard Booth	1-row	1, 2, 3, 4, 5, 6      
	2-row	4, 6, 8, 10, 12     
	3-row	9, 12, 15, 18    
	4-row	16 
	Block format	20, 25, 30, 35, 40, 45, 50, 55, 60, 65, 70, 75, 80, 85, 90, 95, 100
Small Package Booth	1-row	1, 2

- (1) Exhibitors in rows may have booths of other exhibitors on one or three sides.
- (2) Shared exhibit and/or industry organizational exhibits may apply for more than 100 booths.
- (3) After the deadline for applications, the Organizing Committee will determine the layout of the show site. If the total space applied for exceeds the capacity of the site, the Organizing Committee reserves the right to determine an impartial method to reduce the number of booths applied for by exhibitors. The kind understanding of exhibitors on this matter is greatly appreciated.

3-6. Selection of Booth Position

(1) Selection of booth position

Exhibitors can select booth positions from specified locations on a floor plan for booth selection, which is decided by the Organizing Committee. 'Floor plan for booth selection' will be sent to exhibitors from CEATEC Management Office starting the end of June (planned). Exhibitors will be able to choose their booth location at Session for selecting booth position, which will be held in July. Selections will be made in the order in which you submitted the application form on the website.

※Precautions for deciding booth positions

- Area/Zone composition will be carried out based on the exhibitor booth locations. Area/Zone composition will be determined by the Organizing Committee.
- The location of block booths may be decided first on a first-come-first-served basis before conducting Session for Selecting Booth Position, to secure visitor flow line and emergency evacuation flow line, as well as to ensure safety in transporting goods in and out of the venue.
- The booth allocation diagram might be altered even after booth positions have been decided. In this case, booths might be repositioned.
- Since exhibition applications are accepted by a first-come-first-served basis, the date and time of applications received by email or fax will be checked and managed in a fair manner; however if we receive two submissions at the exact same time, CEATEC Management Office will decide between the two exhibitors by considering exhibitor's past results (the number of times participated and exhibit scale) and the status (whether the exhibitor is a member of one of the sponsor organizations).

(2) Spare booth spaces

If booth spaces remain available on Friday, April 26th, the remaining spaces will be placed on the floor as spare booths. Exhibitors submitting applications after Saturday, April 27th must select booths from the spare booths specified on the booth allocation diagram after booth positions have been confirmed for exhibitors who applied before the deadline for Priority Acceptance of Applications. Spare booths will be allocated on a first-come-first-served basis.

(3) Fixed booth spaces

The Organizing Committee has determined the following booth spaces to be fixed:

1. Booths for Japan-related associations
2. Booths for overseas cooperative organizations

(4) Utility booths will be setup in spare open spaces after the booth lot drawing is completed. However, exhibitors should be aware that further changes in booth allocation may occur due to exhibitor cancellations, reduction in booth spaces, etc.

(5) The Organizing Committee may specify the location of booth entrances for exhibitors applying for block booths in consideration of overall visitor flow.

(6) Changes to requested exhibition zones will not be accepted after the deadline for Priority Acceptance of Applications, which is Friday, April 26, 2019.

3-7. Expenses included in the booth fee

(1) Badges

Exhibitor badge	15 badges per booth space
Worker badge	5 badges per booth space

Note: For additional Badges, refer to section 4-1. Expenses other than booth fee.

(2) Show Information Leaflets (Application required)

1 to 3 booths	Up to 1,000
4 to 8 booths	Up to 2,500
9 to 12 booths	Up to 4,000
15 to 20 booths	Up to 6,000
Each additional 5 booths	Increase by 1,200

Notes: For additional Show Information Leaflets, refer to section 4-1. Expenses other than booth fee. There is no need to apply for Show Information Leaflets included in the booth set for Planned Exhibits (Society 5.0 TOWN and Co-Creation PARK).

3-8. Payment of booth fees

Booth space payments are to be paid via electronic bank transfer according to the schedule below. The Association will issue an invoice and designate the bank account for remittance at this time. Checks and promissory notes are not acceptable as payment. Transfer fees are to be borne by the exhibitor.

Booth fee payment deadline	Friday, June 28, 2019
-----------------------------------	------------------------------

3-9. Cancellation or reduction of the number of booths

If an exhibitor cancels or reduces the number of booth spaces applied for, regardless of the reason, some or all of the following cancellation fees will apply. Consumption tax will be added to all fees.

After Saturday, April 27, 2019	100% of booth fee
---------------------------------------	--------------------------

Cancellations or any other changes must be notified by sending a letter via post, fax, or email and will become valid on the day that the notification is delivered to the Association.

4. Expenses Other than Booth Fee

4-1. Expenses other than booth fee

(1) The following items and booth decorations other than base panels are not included in the booth fee:

Primary power source construction cost + Electric consumption fee	11,000JPY/ kW (including consumption tax*)	Extra exhibitor badges (for those exceeding 15 per booth)	Applied before September 27 (Fri) Purchased at the venue	1,650JPY/ badge (including consumption tax*) 3,300JPY/ badge (including consumption tax*)
Overtime working hours fee	11,000JPY/ hour (including consumption tax*)	Extra worker badges (for those exceeding 5 per booth)		550JPY/ badge (including consumption tax*)
		Extra Show Information Leaflets (In excess of the number of aforementioned free leaflets)		330JPY/ leaflet (including consumption tax*)
		Envelope (Material: OPP film/Size: W 120 mm x L 235 mm <W 4.72 in x 9.25 in>; for sending Show Information Leaflets)		22JPY/ envelope (including consumption tax*)

*Consumption tax rate effective at the time of the exhibition, October 2019, will be applied.

(2) Utility booth (Separate application required)

When using the space internally, for storage and break room, etc.

220,000JPY/ booth (including consumption tax*)

*Consumption tax rate effective at the time of the exhibition, October 2019, will be applied.

Note: Owing to space limitations, there may be a maximum availability per exhibitor (or per zone if an exhibitor is exhibiting in multiple zones).

Apply for the utility booth supplied in the Exhibition Guide, which will be distributed at a later date.

1. Specifications 2,970 mm (W) x 2,970 mm (D) x 2,700 mm (H)

2. Fixtures per Utility booth System panel walls, A door with lock, 2 fluorescent lights, 1 electrical outlet with 800 w output

3. Locations Utility booths will be located in the exhibition hall area near the booths, as determined by the Organizing Committee. Because exhibition space is limited, some utility booths may have to be located outside of the exhibition halls.

(3) Others

Separate applications are required and charges will be levied for advertisement menus, promotion menus, and other rental items such as lighting and carpets, as well as for gas and water usage. Also, additional fees may arise owing to the regulations relating to booth design, or exhibitors requests. Details will be announced in the Exhibition Manual, which will be distributed at a later date.

4-2. Payment other than booth fee

Booth space payments are to be paid via electronic bank transfer according to the schedule below. Checks and promissory notes are not acceptable as payment. Bank transfer fees are to be borne by the exhibitor. Designated bank account for remittance will be announced at the time of billing and billing source will be announced in the Exhibition Manual, which will be distributed at a later date.

Deadline for the payment other than booth fee

Friday, December 27, 2019

5. Important Exhibit Details and Prohibitions

5-1. Exhibiting of products from outside of Japan (including fixtures)

The Association will apply for a bonded exhibition area in respect of the entire exhibition hall. If such application is granted, it will allow exhibitors to display foreign products (i.e. goods produced or manufactured outside Japan which have not yet undergone customs clearance) without customs clearance.

Note: Submission of application is required for these items. Details will be made available on the Exhibition Manual.

5-2. Protection of exhibited items for which application for industrial property rights has not been filed

Part of the Patent Law has been revised and the application items of regulations concerning exception to lack of novelty of invention have been reviewed. Due to this revised law, the designated system of exhibitions will be abolished from 1st April, 2012, and disclosure type restrictions will be removed from the old system where application items were restricted except for certain exhibitions. Exhibitors who plan to file an application for patent, utility model or trademark, should directly contact the General Affairs Division of the Patent Office.

5-3. Prohibited activities

The following activities are prohibited:

- (1) Exhibit space transfer
Subletting, selling, transferring, or exchanging exhibition space, either in whole or in part, to any third party, including other exhibitors.
- (2) Directing visitors to other venues
Directing CEATEC visitors to simultaneous product or technology exhibits off-site is prohibited.
- (3) Engaging in sales activities
Selling products other than publications and software on-site during the show is prohibited. Exhibitors who wish to sell publications or software are required to submit details and seek approval from the Association when applying for the exhibition.
- (4) Inappropriate behavior
Aggressively attempting to attract visitors to view demonstrations while standing outside of booths or in aisles is prohibited. Persistent sales approaches and/or techniques considered to be excessive are also prohibited.
- (5) Exhibiting for the purpose of obtaining personal information
It is prohibited to use booths for the primary purpose of collecting personal information on visitors, rather than to display or to conduct PR of products and services. Furthermore, all exhibitors are requested to abide by the stipulations in Japan's personal information protection legislation. Details on the collection and handling of personal information will be available in the Exhibition Manual.

5-4. Responsibilities of exhibitors

- (1) Prompt fee payment
Exhibitors must pay all exhibition fees and expenses invoiced by The Association and bear responsibility until all payments are complete.
- (2) Obeying the law
Exhibitors must abide strictly by the laws and regulations of Japan.
- (3) Liability for damage, management of exhibited items, and insurance
1. The sponsors (CEATEC Executive Board comprised of JEITA, CIAJ, and CSAJ), the Organizing Committee and the Association will make every effort to ensure the security of exhibits during the show period, for example, by implementing security guard patrols. However, CEATEC sponsors, the Organizing Committee, and/or the Association cannot assume responsibility for damages from natural disaster, fire, theft, loss of property or other occurrences beyond its control and recommends that exhibitors take steps of their own.
2. Exhibitors shall be liable for any fatalities or injuries occurring to visitors, other exhibitors or third parties as well as damage to items at the exhibition site. CEATEC sponsors, the

Organizing Committee, and/or the Association shall bear no responsibility whatsoever in such circumstances.

3. A booth manager, whose responsibility is to supervise all activities that take place in the exhibitor's booth, must be confirmed with the Association prior to the start of the exhibition.
4. Exhibitors are recommended to provide for adequate insurance coverage during the exhibition.
5. The Association will make every effort to provide effective management, enhanced safety, and maintenance of order at the venue as well as ensure the safety of exhibition visitors. Any act by an exhibitor(s) that is considered detrimental to the aforementioned may lead to the termination of that exhibitor's demonstration. Exhibitors shall be liable for any accidents that may occur during exhibitor demonstrations, and CEATEC Sponsors and/or the Executive Committee and/or Association shall bear no responsibility whatsoever in such circumstances. In the event of an accident, the exhibitor is required to take appropriate action and report it immediately to the Association.
- (4) Complying with the exhibition schedule
Prior, during and after the exhibition, all exhibitors are requested to comply with the exhibition schedule specified by the organizer. Construction activities to the booth, delivery and/or wrap-up activities during the exhibition are prohibited.

5-5. Termination or shortening of exhibition duration due to force majeure

- (1) If the exhibition is canceled because of an event of force majeure, such as an earthquake, typhoon, fire, disease, terrorist act or order from the public authorities, the organizers reserve the right to shorten the duration of the exhibition or the hours that the exhibition is open to the public, either before or during the exhibition. If the exhibition sponsors deem such action necessary, this information will be promptly published on the official Website and exhibitors will be notified. Neither the exhibition organizers nor the Association shall assume any liability for losses incurred by exhibitors in such a case.
- (2) If a force majeure which has occurred prior to the opening of CEATEC forces the exhibition to be cancelled, the Association will refund participation fees paid by exhibitors in full, minus charges for expenses incurred.
- (3) However, if the duration of the exhibition is shortened by a force majeure after CEATEC is commenced, the Association shall not be held liable to refund either full or partial exhibition expenses.
- (4) The Association assumes no responsibility for other expenses already incurred by exhibitors.

5-6. News gathering and filming

Staff members appointed by the Association and/or the Organizing Committee will be authorized to gather news and/or conduct interviews as well as engage in filming and/or photography. Exhibitors are requested to cooperate with such news gathering and filming activities and also agree that any exhibited items, or any image, photograph, information, etc., obtained during the exhibition will be used by the Organizing Committee or an organization authorized by the Association for the purpose of publicizing and/or promoting CEATEC.

5-7. Dealing with disputes between exhibitors

Any disputes between exhibitors concerning exhibits, publicity materials related to exhibits, intellectual property or the use of booths shall be resolved between the parties concerned. The exhibition sponsors shall bear no responsibility whatsoever in such instances.

6. Booth Setup

6-1. Booth designing

Product exhibits, demonstrations, etc., must be conducted within the exhibitor's booth. If for some reason the following rules are not complied, the exhibitor will be demanded for improvement from the Organizing Committee and/or the Association; any further noncompliance may result in termination of the exhibitor's booth.

- (1) Safety Measures
1. To prevent truss beams falling, strike four or more anchor bolts in one place when securing them to the floor.

- When installing exhibition panels (OCTANORM), take measures to prevent them falling by reinforcing the panels, reinforcing the beams in the corner sections, and installing weights.
 - Take measures to prevent independent fixtures falling by securing them to the wall or floor surface.
 - When installing video monitors, speakers, channel characters, lighting fixtures, and other fixtures.
 - Maintaining visitor flow lines of adjacent exhibitors
- When designing block booth, be sure to keep 1/3 (one-third) of the side adjacent to the aisle open to allow for an evacuation route.
- (3) Installing stage and video equipment
- When setting up video equipment or a stage for a production presentation or similar demonstration in a booth, please ensure that there is plenty of room for visitors, so that they do not block the aisles. Furthermore, depending on the height of the stage and the video equipment to be installed, please take sufficient care of the visitors viewing angle and make sure there is an appropriate viewing distance. The organizer will check the booths and if any discrepancies are noted, may ask for modifications to be made.

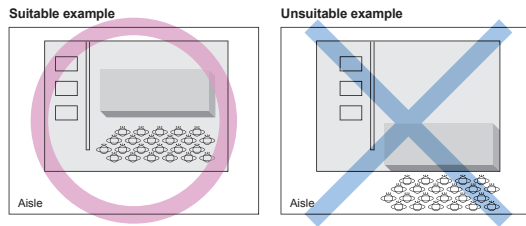

- (4) Speaker setup position restrictions
- The positioning of speakers and other audio equipment towards adjacent booths is not permitted. Also, when setting up speakers on a wall or stand, the center axis should be facing downward, within 45° from the floor to the center axis of the speaker, and the center axis shall not extend out of the booth space.

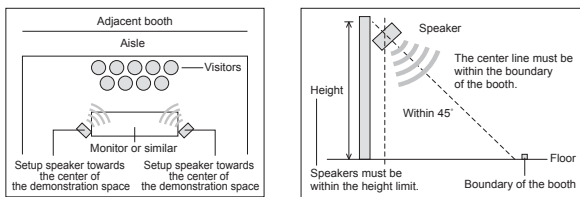

- (5) Prohibition of using space other than within the booth
- Visitors must not be allowed to block aisles around the booth. When setting up a stage or similar demonstration, ensure that the booth can accommodate a large number of visitors, if expected.
 - Calling out to visitors from outside of the booth, having visitors fill out questionnaires outside of the booth, or similar activities are prohibited.
 - Presentation acts using the aisles around the booth or outside the booth is prohibited. Furthermore, product exhibits, fixtures, catalogs, equipment, plants, packaging materials and visitor waiting lines cannot be placed in aisles around the booth or behind the booth.
 - Lighting directed toward aisles, exhibition hall walls or ceiling is prohibited.
- (6) Booth space boundaries
- Regarding a block of booths (20 booths or more), please be sure to take into account when constructing the booth space to make it clear to visitors where the aisles and boundaries are, by installing carpets and the like.

6-2. Ceiling installation

Installing a ceiling on the booth is only permitted when products and/or demonstrations need to be shielded from light or sound. The ceiling must be made of a fireproof blacked-out curtain, which is the only material permitted under local fire department restrictions. Direct sunshine will be blocked out within the exhibit halls but there still may be some reflections cast from the indirect and ceiling lighting. Exhibitors who wish to set up ceiling structures, without regard to the size or area, are required to submit an application form sent with the Exhibit Manual together with top and elevated view booth drawings. Observe the following guidelines for the design and construction of a ceiling structure.

- (1) Structure
- Any double layer structure is prohibited.
 - All the decorating materials must be fire-resistant processed and attached the fire-resistant indications.
 - Exhibitors are required to submit both top (designated ceiling area and its size) and elevated view (designated ceiling area and surrounding wall, etc.) booth drawings. They must show that the ceiling are fire-resistant processed.
- (2) Fire Safety Equipment
- Fire extinguishers must be size 10 or larger.
 - Fire alarms (smoke alarms) may be required. In such case, exhibitors must submit the placement notice and its operation experiment result to the Association. Domestic fire alarms are not accepted.
 - Depending on the structure or size, evacuation exits and leading light for emergency may be necessary.

6-3. Two-floor construction

A two-floor construction is defined as a layered structure with flow lines for the traffic of people on the upper floor with an overall height exceeding 2.1m from the surface floor. However, even when the booth structure height does not reach 2.1m, the structure is considered to be a two-floor construction if the base floor is used as an aisle, product exhibit, waiting room, etc. Please note that approval from the local fire department is required for the construction of a two-floor structure.

Exhibitors who wish to set up a two-floor booth structures are required to submit an application form sent with the Exhibit Manual together with a construction plan. Observe the following guidelines for the design and construction of a two-floor structure.

- (1) Booth requirements for construction
- Exhibitors using more than a block of booths (20 or more booth spaces) are allowed to construct a two-floor structure.
- (2) 2nd floor floorage
- The upper limit of floorage for the 2nd floor shall be a half of the exhibit area (a maximum of 500 square meters including the slope area).
- (3) Height of the 2nd floor structure
- The maximum height of exhibited products and fixtures is 6m so this height should also be maintained for items on the 2nd floor.
- (4) Use of the 2nd floor structure
- The 2nd floor structure can be used as a product exhibition area, a business meeting room, a waiting room, and an operations room, etc. This structure must also be set back at least 1m from the border of the aisle and booth. Demonstrations from the 2nd floor to visitors on the 1st floor are prohibited.

- (5) Design
- When designing the 2nd floor structure, calculate the load of the 2nd floor (including an estimate of maximum load capacity) using the diagram shown below. Note that a ceiling cannot be installed for the 2nd floor.
- Design a safe structure that is made of steel (aluminum truss is also acceptable) and can withstand a seismic load caused by a major earthquake in addition to the above described load.
 - While the Association may request materials showing your structural calculations; setting the design conditions is the responsibility of exhibitors, so be sure to take safety aspects fully into consideration when doing so.
 - Make sure to fill in Structural designer in the Application for Two-Story Booth Structures.
 - At least two stairways, each at least 90cm wide, need to be installed.

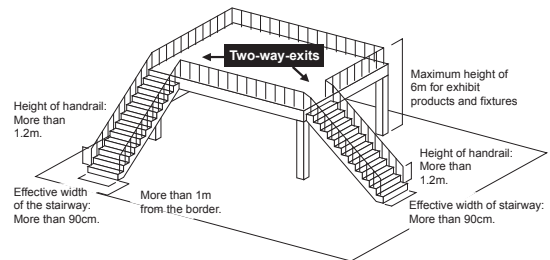

- (6) Fire prevention and evacuation installations, etc.
- The following fire-prevention measures must be taken for a two-story structure.
- Automatic smoke alarms and fire extinguishing equipment are mandatory for a two-story structure. Fire extinguishers (type 10 or larger) must be installed on the 2nd floor.
 - Before installing a fire alarm or smoke alarm, notification of its placement and operation test results must be submitted to the Association. Smoke alarms for domestic use are not acceptable.
 - There must be at least one fire alarm (smoke alarm) per 150m² of ceiling of the 1st floor. If a 60cm or longer wall is hung down from the ceiling, at least one fire alarm (smoke alarm) must be set in each enclosed area.
 - For the 2nd floor with an area of more than 200m², fire alarms (smoke alarms) must be connected directly to the control office of Makuhari Messe. Other fire safety equipment may be required to be installed. We recommend contacting the control office at your earliest convenience, as other fire safety equipment may be required for installation.
 - Plywood, fiberglass materials, carpets, curtains, tablecloths, coverings, and banners for the exhibit must all have fireproof labeling; usage without labeling is strictly prohibited.
 - For the 2nd floor with an area of 100m² or more, a certified fire prevention officer must be stationed on-site.

6-4. Ceiling-suspension configuration

A suspension configuration is defined as a method of exhibiting by constructing a booth that suspends fixtures via chains hanging from the ceiling. Exhibitors who would like to set up suspended structures are required to submit an application form sent with the Exhibit Manual together with a statement of total weight, top and elevated view drawing.

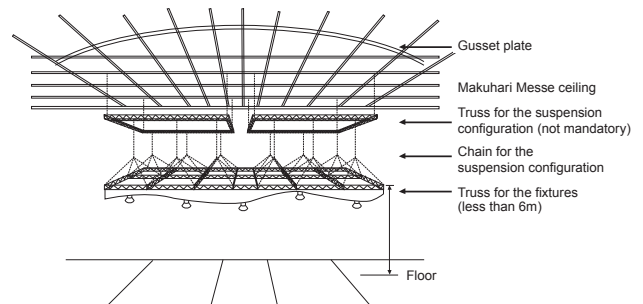

- (1) Booth requirements for usage
- Exhibitors using more than a block booth (20 or more booth spaces) are allowed to use the suspension configuration.
- (2) Space restrictions
- Space is restricted to within the perpendicular line from the booth's internal surface. But even if the suspension configuration meets this restriction, if its location interferes with the deluge gun in the exhibit hall, the suspended item will have to be repositioned.
- (3) Suspension base restriction
- As a rule, suspension base should be done on gusset plates. If the use of other locations (e.g. beams, etc.), please contact the Association at early stage. Depending on the weight, construction plan may be asked to change.
- (4) Load (weight) limitation
- The gusset plate for a single suspension must weigh less than 450kg. Exhibitors are required to submit the construction plan and a statement of total weight that specify the weight of each gusset plate. Construction plan which all suspension weight divided by the number of suspension base point cannot be accepted.
- (5) Height limitation
- Fixtures (e.g. metal and/or wooden structures, signage, lighting, speakers, banners, cloth materials) must be less than 6m in height. However, trusses for the suspension configuration such as chain motor boxes are not applicable for the height limitation but they should be installed in areas that will not disturb the view of surrounding exhibitors. And for safety reasons, the chain for suspending truss must be installed within a meter above the truss fixture. The exhibitor is responsible for any of the costs related to the change of plan.
- (6) Other limitations/considerations
- Design ornamental trusses to have a combined structure that is not separated in pieces.
 - Design suspended trusses to prevent impact from horizontal vibrations caused by an earthquake and secure as much distance as possible between installed trusses.
 - Ornamental trusses and decorations built from the ground must be designed so that they are not secured by being tied with material such as wire. In regard to the wiring of cables that cross the floor to the ornamental truss, design it so that it can prevent disconnection from horizontal vibrations caused by an earthquake and can be installed flexibly.
 - When installing monitors, speaker channel letterings, and/or lightings on ornamental trusses, take measures such as securing with bolts or wires to prevent from falling.
 - Only use unobtrusive colors such as black and gray for components such as trusses.
 - Exhibitors that install suspended trusses shall assume full responsibility for accidents that occur during the construction of the suspended structure or are caused by the suspended structure during the exhibition period.
 - When selecting booth positions, the exhibition layout from the office clearly indicates areas

where structures can be suspended from the ceiling. If an area other than an area where ceiling-suspended structures are possible is selected, and the exhibitor suspends structures, the exhibitor will be liable for cost incurred etc.

6-5. Floor construction work

Exhibitors who require floor construction work are required to submit an application form sent with the Exhibit Manual together with a floor plan. Observe the following guidelines for the Floor Construction Work.

(1) Floor Construction Work

- Exhibitors are required to contact CEATEC Management Office in each hall before commencing the work and inform the number of anchor bolts to be affixed.
*In case there is no need of anchor bolts, exhibitors are required to submit the cancellation
- Concrete nails and jackhammering are prohibited. No construction may be carried out on pit covers or pit interiors on the floors.
- To prevent truss beams falling, strike four or more anchor bolts in one place when securing them to the floor.
- Carpeting a booth, exhibitions are required to use double-faced tape. Use of glue is prohibited.
- Restoration to original condition
Floor construction work is permitted on the condition that all flooring will be restored to its original state after the show. After usage, if the bolt heads project above the surface, they must be sawn off, not hammered in or cut with acetylene torches. All expenses for restoration shall be borne by the exhibitor. In the event that the floor is not restored to its original condition after the final floor inspection, or the restoration is incomplete, the Association will complete the restoration work and charge the total amount of expenses to the exhibitor after the show.
- Floor restoration expenses
When bolting down an anchor bolt, a cooperative fee for the restoration of floor surfaces of 1,100JPY per bolt (including consumption tax) will be charged to the exhibitor, regardless of the size of the bolt.

6-6. Fire prevention regulations

In the initial construction stages and during the exhibition, inspections will be conducted by the local fire department. If it is determined during the inspections that the following regulations are not being observed, termination of construction and/or removal of the booth(s) may be ordered.

- If a thick fabric or fabric with ruffles (pleats) is to be attached on the fireproof plywood of the booth, it must have fireproof properties. Use of a fireproof fabric is not necessary, however, when thin processed paper or fabric is used on the surface of the fireproof plywood.
- Thick stage curtains, ordinary curtains, plywood for display use, fiberglass boards, blinds made of fabric, black-out curtains, artificial flowers, carpets, flooring materials, sheets for construction, and any other materials used must all have fireproof properties. The fireproof labeling on each item must be shown in a clearly visible location.
- The use of materials such as Hong Kong flowers, urethane, acetate, polyester, and nylon is prohibited as they are highly combustible.
- The use of expanded or foamed polystyrene is also prohibited, it is recommended that Styrofoam or a similar material be used instead.

7. Exhibited Items and Management

7-1. Counterfeit or imitation products are strictly prohibited

- The display, distribution, or demonstration of counterfeit or imitation products that infringe on a third party's intellectual property rights (e.g. patents, trademarks, design rights, copyrights, overseas rights, etc.) or any other related activity is strictly prohibited.
- If the Organizing Committee and/or the Association discovers counterfeit or imitation products being displayed, distributed, or demonstrated, it reserves the right to remove these products from the exhibition venue immediately with all costs incurred becoming the responsibility of the offending exhibitor.
- In addition to inspections for counterfeit or imitation products, all exhibitors shall cooperate with the Organizing Committee and/or the Association whenever any type of inspection is conducted.
- Any disputes concerning the intellectual property rights of exhibited products shall be resolved between the parties concerned.

7-2. Comparison displays

As a general rule, exhibitors are requested to limit product comparisons (see guidelines below) to demonstrations between products and/or technologies of their own company or group companies. Exhibitors who plan to compare their products or technologies with those of other companies should first obtain advance permission from the other company and such comparisons must not infringe upon the property rights of that company. When the Association and/or Organizing Committee determine that the following guidelines on comparison displays have not been observed, they reserve the right to terminate the display or order that corrective measures be taken with all costs incurred by the exhibitor. If said corrective measures are determined to be insufficient, the exhibitor may be barred from future participation in CEATEC.

- Comparisons using exhibits and demonstrations
- Comparisons using information panels and pamphlets
- Verbal comparisons in audio announcements
- Other comparisons related to products and technologies

7-3. Suitable displays

The following regulations must be strictly observed for all displays in the exhibition booths.

- Safety and precaution signage
All booths must have adequate safety and precaution signage positioned in clearly visible locations around the displays.
- Displays should reflect real-life situations
Product presentations and/or displays should be demonstrated in real-life situations as much as possible and not in an exaggerated or unrealistic manner. If this is not practical, the product(s) must have accompanying captions stating how they are used in actual applications.

7-4. Display-area lighting

The brightness of the venue is between 450 and 500 lux when all high-pressure mercury ceiling lamps are lit. There are four mercury ceiling lamps per block in the exhibition hall; however taking the exhibition environment into consideration, lighting will be kept within 3/4 of the total brightness for all areas.

7-5. Restrictions on audio volume

Before installing audio equipment in the booth, discuss with the surrounding exhibitors and set the volume so that they do not disturb each other. When explaining products or making demonstrations using audio equipment, try to break down the time as much as possible. Also discuss with your neighbors on adjusting the presentation microphone audio level, and the time-frame of each presentation. Stop the audio immediately when there is an emergency broadcasting at the venue.

- Audio output limitation
Maximum of 80dB
- Volume measurement
As a general rule, the standard values are to be measured 2m away from the booth border line.

- The peak value, which is measured by devices meeting the JIS C1509 standard, is used for assessment.
 - The Association staff will periodically measure volume levels during the exhibition, however, it is required that exhibitors also measure volume levels before and during the exhibition. Decibel meters are available from the Association, so please do not hesitate to ask for one.
- Measures for exhibitors violating the volume restrictions
If volume levels are determined to exceed the aforementioned limits, or the exhibitor generates deep bass sound that may be disturbing to surrounding exhibitors, the exhibitor will be advised for improvement and required to follow the instructions. Even if the audio level is within the aforementioned limits, the exhibitor will be advised to modify their audio equipment accordingly if the sound coming from the booth is determined to be bothersome to surrounding exhibitors and visitors. Such exhibitor will be penalized with the following if the exhibitor makes no improvements.
 - When the exhibitor is advised for improvements for the third time: Ban the use of audio equipment from the morning of the following exhibition day.
 - Stationing a person responsible of operations
Please make sure that a person responsible for audio equipment is stationed in your booth at all times, and that the audio equipment is operated in accordance with the regulations.

7-6. Demonstration regulations

- Copyright procedures
For exhibits and demonstrations featuring musical performances, audiovisual presentations, etc., copyright procedures must be processed (not necessary for copyrights owned by your company and already processed). For more information concerning the necessary procedures for obtaining permission from copyright holders, contact the Japanese Society for Rights of Authors, Composers and Publishers (JASRAC)
- Illumination/Lighting
Nothing may be directly attached, nor may lights be shone directly onto the walls, floors or ceiling of Makuhari Messe. When strong lighting equipment such as LEDs are used in displays and/or signboards, they must be positioned so as not to inconvenience visitors or neighboring booths. If any problems occur in line with lighting, The Association will request immediate countermeasures.
- Smoke machines
The use of smoke machines (including alcohol, oil or petroleum smoke machines, and dry ice machines) is not permitted.
- Miscellaneous
If the exhibit planned incorporates any of the items listed below, please take the necessary steps to ensure that the exhibit will not affect the surrounding booths and/or exhibition visitors in any way.
 - Hot air
 - Gas
 - Strong smells or fragrances
 - Vibrations

7-7. Handling of hazardous items

- Prohibited activities
 - Smoking
 - Use of open flame (including pyrotechnic devices, exposed electro-thermal devices, etc.)
 - Use of liquefied petroleum gas or any other inflammable gas in the venue.
 - Use of flammable substances such as gasoline, kerosene, machine oil, heavy oils, etc., in the venue.
 - Use of hazardous items such as explosives, large amounts of matches or disposable lighters, etc., in the venue.
- Exemptions for prohibited activities
Excluding smoking, exemptions for prohibited activities and/or the use of some of the aforementioned substances may be granted by local fire safety authorities if it is determined that only minimal amounts of substances will be used or that the activities are necessary to enhance the exhibit. For exhibitors seeking exemptions, please fill in the relevant items on the "Hazardous Materials Usage Application" in the Exhibition Manual and submit the form together with two declaration copies explaining the nature of the performance or exhibit. The Association will submit all applications to the fire safety authorities at a single time, and only the items granted exemptions will be allowed to be used in the venue.

8. Violation of the Regulations and Discrepancies in Interpretation/ Others / Organizing Committee

8-1. Violation of the regulations and discrepancies in interpretation

If an exhibitor violates these Regulations or if there is a discrepancy in interpretation or the application of these Regulations, the following measures will be taken. Please note that the interpretation of the Regulations as defined in the original Japanese language documentation will take precedence.

- If the Organizing Committee determines that an exhibitor has violated Regulations governing exhibitor booths and implementation of exhibits, the Association will request that the exhibitor take the necessary corrective measures.
- If the same violation described above (section 1) occurs again, or a discrepancy in interpretation of these regulations occurs, the Organizing Committee will take the appropriate action and based on its final judgement, order the exhibitor in question to take the necessary corrective measures. Please note that once the Committee reaches a final ruling, the Committee will not enter into any further discussion with the exhibitor, nor be responsible for any incurred liabilities whatsoever.
- If an exhibitor has been ordered to take corrective measures described above (section 2), the exhibitor will be required to submit in writing on the same day, a description of the necessary corrective measures taken and the schedule at which they will be completed.
- If an exhibitor has been ordered to take corrective measures described above (section 3), and fails to do so accordingly, or if the corrective measures taken are determined to be insufficient by the Organizing Committee, the following penalties may apply.
 - The exhibitor will be prohibited from continuing with exhibition activities from the next day.
 - If the penalty in section "1" above is ignored, the exhibitor will be barred from exhibiting at the subsequent CEATEC exhibition.

8-2. Others

- Other prohibited activities and regulations that are not included in these Regulations will be detailed in the Exhibition Manual that will be distributed later.
- Promissory notes cannot be accepted for payment for booth fees and all other expenses.
- These Regulations are subject to change as deemed necessary by the show sponsors, the Organizing Committee or the Association. If changes occur to the Regulations, they will be posted on the CEATEC Official Website, or brought to the attention of exhibitors by other means.
- Observing these Regulations is the sole responsibility of the exhibitor. The show sponsors, Organizing Committee and the Association will not accept any responsibility resulting from violations of existing laws and/or local ordinances by exhibitors.

8-3. Organizing Committee

Comprised of exhibitor representatives, the Organizing Committee's role is to consider problem areas and reach appropriate decisions concerning the control, planning, and operation of the exhibition. The Organizing Committee is present during show preparations and during the exhibition to ensure a proper exhibition environment and solve problems should they arise. The Organizing Committee has the authority to enforce all regulations and will act accordingly should any violations occur.

Event Schedule (Tentative)

19th (Tue.) 10:00a.m. (JST)
Start accepting exhibit applications

Important [Company/Organization Exhibits]
 Exhibitors can select booth position from those on the booth allocation diagram determined by the CEATEC 2019 Organizing Committee. Booth selection will be given preference in the order in which you submitted the application form on the website. (Refer to page 20, section 3-6. Selection of Booth Position in the Exhibition Regulations)

26th (Fri.)
Deadline for Priority Acceptance of Exhibit Applications

28th (Fri.)
Booth fee payment due date

Early Exhibitors Briefing/ Session for selecting booth position
Mid Admission pre-registration starts
Start accepting reservations for Key Note Speeches
Distribution of an Official Press Release

Mid Start accepting reservations for all conferences
Distribution of an Official Press Release

Late Distribution of tools for attracting visitors, vehicle passes and exhibitor badges

Early Exchange gathering with other exhibitors

Mid Exchange gathering with the press

12th (Sat.) to 14th (Mon.) Preparation

 12th (Sat.) from 8:00: Preparation for exhibitors with more than 20 booths
 12th (Sat.) from noon: Preparation for all exhibitors

14th (Mon.) afternoon: Media Convention

October 15th (Tue.) ~ 18th (Fri.)

CEATEC 2019

18th (Fri.) 17:00 ~ 22:00: Dismantling and removal

Priority Acceptance Period of Exhibit Applications

Exhibitors can choose booth position from the booths specified on the booth allocation diagram in the order in which you submitted the application form on the website.

Acceptance Period of Additional Exhibitor Applications

Exhibitors still have the chance to choose booth position from Saturday, April 27th as long as there are booth spaces remaining after booth position has been confirmed for exhibitors who applied during the priority acceptance period. An exhibitor can choose booth position from the remaining booth spaces specified on the booth allocation diagram. Booths will be allocated on a first-come-first-served basis.

The office will end acceptance of exhibit applications as soon as all booth spaces are taken.

Example of Exhibitor Preparation Schedule

